



Gen 2—the Definitive, Myth-Busting, Item-Level Solution

Bringing the benefits of UHF Gen 2 to item-level tagging enables a single, worldwide RFID infrastructure

RFID has been around a long time. But things have changed rapidly in the last two years, and new opportunities abound. Older formats use relatively low frequencies, whereas a resurgence of interest in RFID has attended the use of ultrahigh frequencies (UHF). This technology has made operation over phenomenally long ranges possible, opening up entirely new applications in supply chain management.

The question is: can long and short-range operation coexist? Certainly there are applications in which one or the other must dominate. The answer is a resounding *yes*: for the first time, and enabled by the physics of RF propagation at UHF, RFID tags can be made to serve multiple masters.

Gen 2—the RFID Standard that Covers the Application Spectrum Worldwide

UHF Gen 2 was designed from the ground up to 1) solve the well-known problems associated with incompatible, poorly performing, functionally-compromised, and proprietary RFID standards, and 2) advance a single, worldwide standard that would actually make possible practical and economical proliferation of RFID throughout the supply chain. Thankfully, both goals were achieved. In putting forth a truly robust protocol, Gen 2 also greatly expanded the potential of RFID systems by providing such features as dense-reader mode, significantly higher data rates, greater security, a means for worldwide operation, as well as special inventory-enhancing functions including "select" and "sessions," and the flexibility to tailor the system to meet the demands of its operating environment. Furthermore, the single standard means that for the first time, interoperability among competing Gen 2 providers is also possible. All of the foregoing factors combine to make Gen 2 the most economically viable RFID solution available both now and going forward. And, we now know that Gen 2's many benefits readily extend to item-level tagging applications. With that assertion, let's explode a few myths. But first, a few words about the way RF behaves will lay the groundwork for the discussion that follows.

Playing the Field

Simply stated, there are two components of the RF wave: magnetic and electric. Generally speaking, HF RFID (13.56 MHz) relies on the "near-field" *magnetic* aspect of the field, while long-range UHF RFID (860–960 MHz) exploits "far-field" radiation (which consists of both electric and magnetic components). Both elements are present regardless of the frequency of operation. But just which part of the RF emanation a tag responds to depends on two things: the tag antenna, and its distance from the reader.

Because the magnetic component of the wave diminishes greatly in strength over a relatively short distance, it is characterized as *near-field*; that is, its effective range is limited by antenna geometry to about one or two wavelengths. And because HF tags rely on inductive coupling to this magnetic component in order to receive power, the HF tag antenna is made up of an inductive, coil-like structure that requires additional layers, considerable conductive material, interconnects between layers, and the associated manufacturing complications. Fortunately HF tags have no corner on the item-level market; with the right antenna, UHF tags can just as easily harvest the same near-field magnetic energy—and do so more efficiently and cost-effectively.

The Seven Things They Said You Couldn't Do With UHF

With apologies to George Carlin, we'll borrow his infamous tag line (pun intended) to expose the fiction inherent in the UHF/HF battle of the airwaves. Much has been said and published regarding the merits of HF for ILT, yet much of the widely disseminated information concerning HF has recently been demonstrated to be misleading, incomplete, or just plain wrong. Here are seven examples:

Myth #1: Gen 2 tags are just too big for ILT applications

Tag antenna design is concerned with managing a number of practical tradeoffs—the desired mix of size, cost, orientation, and range—for the application at hand. Some might be optimized for a particular frequency band, while others might be tuned for good performance when attached to materials with particular dielectric characteristics (cardboard versus glass, for example). Others still might be more general purpose in scope, working reasonably well across the entire UHF spectrum, in free space or affixed to an item. And, for purposes of this discussion, they may also be designed to be sensitive to either the near-field or far-field component of the reader's radiating energy.

Now, a Gen 2 tag designed for a warehouse application that requires both long read/write range and orientation indifference is, necessarily, a large tag; a typical example measures 80 mm square (see Figure 1). Yet the same Gen 2 chip fitted with a near-field antenna can be as small as 9 mm round—*considerably* smaller than the vast majority of HF tag offerings! The notion that Gen 2 UHF tags are too large for ILT is, therefore, completely unfounded; they can, in fact, be much smaller than the typical HF solution, *and* exhibit better read reliability in the bargain.

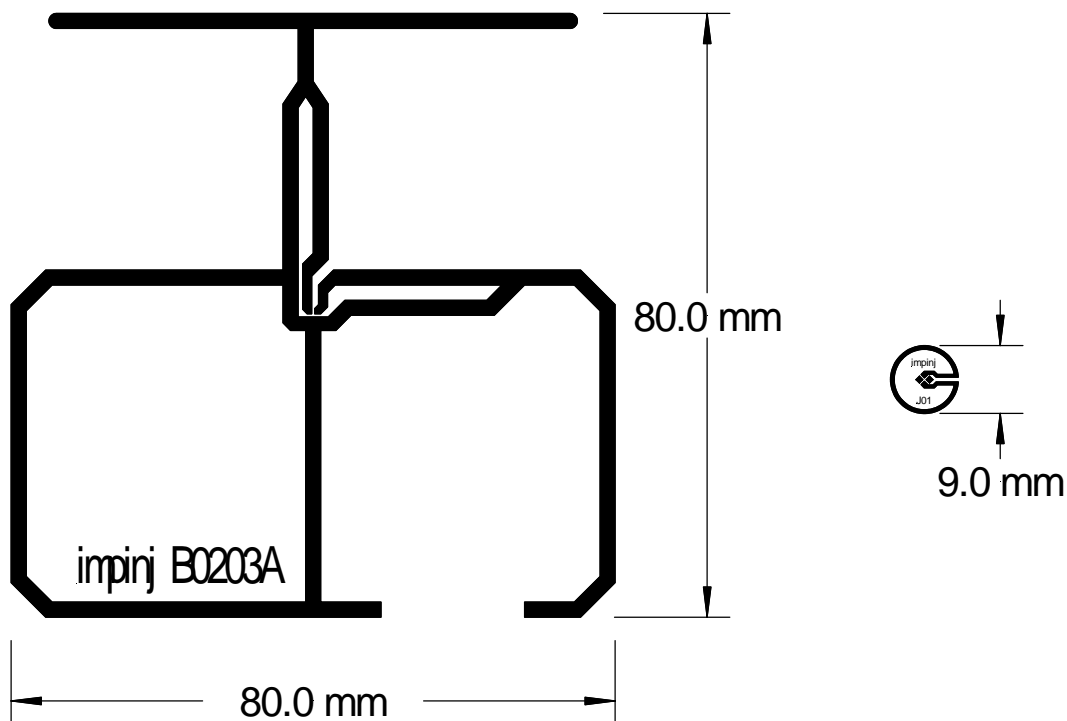

Figure 1 Impinj UHF antenna designs for long-range, multi-orientation warehouse applications (L) and near-field item-level tagging applications (R). The drawings are shown at scale.

Myth #2: HF's 13.56 MHz is the true worldwide RFID frequency for ILT

While the 13.56 MHz *frequency* may be in common use, the communications *protocols* for HF are certainly not universal. A number of competing, and therefore non-interoperable, standards vie for dominance in the HF space, while UHF enjoys a single worldwide standard that has been ratified by EPCglobal™, endorsed by every major commercial concern, and adopted by ISO in the form of its 18000-6C specification. There is one global standard for RFID, and it is Gen 2. And while generally targeted to long-range applications, because it represents a superset of RF capacity, there is plenty of room for short range, item-level applications to come under the same big Gen 2 tent. Furthermore, Impinj has designed its Monza™ tag silicon for high performance in every region of the world. In fact, assuming properly designed tag silicon such as Monza, designing a tag antenna to cover all the worldwide frequencies is straightforward. With a single standard and tags that work everywhere, UHF is indeed the true worldwide frequency for RFID tagging of items, cases, and pallets.

Finally, any discussion of frequency comparisons would not be complete without a reference to Faraday's law, which proves that the effect of magnetic coupling is intensified as the frequency increases (theoretically, for the lower limit of the UHF band, the magnetic coupling strength could be as much as 63 times greater than that of HF!). This is a fundamental advantage of UHF Gen 2 (860–960 MHz) over HF (13.56 MHz), one result of which being the ability to use a very small, single turn, single layer loop antenna that can be printed with low-cost conductive ink. Contrast this to HF's requirement for complex, multi-turn coils that must be etched from aluminum or copper, and support an extra feedthrough layer that doubles the manufacturing complexity of the inlay. In terms of cost and performance, the UHF frequency range is a clearly superior solution, and therefore, the best choice on which to build a worldwide standard.

Myth #3: UHF Gen 2 won't work on liquid-based products

It is true that UHF's short wavelengths tend to get absorbed by liquids, close proximity to which alters the performance characteristics of the antenna, effectively detuning it, and reducing its range. However, these considerations apply only to UHF's *electric* far-field component—not the magnetic near field. In near-field practice, a Gen 2 tag works on liquid-based products just as well, if not better than, HF solutions. To prove the point, Impinj designed a Monza tag silicon/antenna combination that works exceptionally well when applied to a liquid-filled vial—and reads just as reliably when placed *inside* the vial, completely *submerged* in liquid (see Figure 2)! The fact is, item-level applications that emphasize magnetic field coupling—whether HF or UHF—are completely unaffected by liquids.

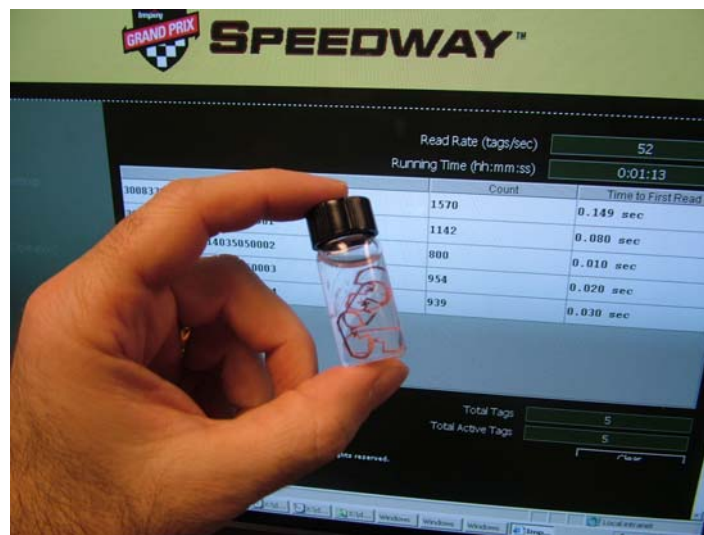

Figure 2 Monza-driven item-level tags read even *inside* a water-filled vial.

UHF Gen 2 for Item-level Tagging

Myth #4: UHF Gen 2 won't work on metallic products

It is also true that UHF's short wavelengths tend to get reflected by metals, but again, this trait comes into play only when considering its far-field performance; near-field UHF performance is quite another matter. Because a properly designed UHF tag antenna is able to exploit the near and/or far field, it can actually use to its *advantage* the metal to which it is attached! This is something that cannot be said of HF tags, which lack the means for electric field coupling.

Myth #5: UHF Gen 2 won't work on items in very close proximity to each other

UHF tags, with their simple structure and single loop design, result in much less magnetic shielding than the dense coils of HF tags. And less shielding allows greater "visibility" to all the tags in the field—especially those that are further away from the reader (see Figure 3). Accordingly, for stacked goods such as DVDs (see Figure 4) and video games, UHF ensures much higher read reliability. What's more, Gen 2's anti-collision algorithm is far superior to the HF protocols when it comes to dealing with large populations of tags placed in close proximity, a scenario typical of retail shelf applications.

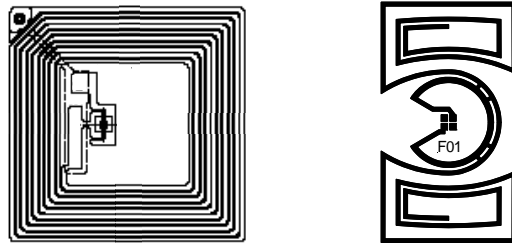

Figure 3 Typical HF tag antenna (L), featuring a dense copper coil layout that results in magnetic shielding of adjacent tags. Impinj's UHF equivalent tag antenna (R) is both smaller and more structurally open. This antenna also exhibits both near-field and far-field performance characteristics.

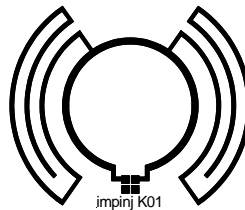

Figure 4 UHF tag antenna designed for DVD.

Myth #6: UHF Gen 2 tags have too great a range for ILT applications

It is true that a defining characteristic of UHF Gen 2 tags is long-range read/write performance. But once users understand that UHF tags can also exploit the near field just as easily as HF tags, this argument is closed. The fact is a UHF tag antenna can be tailored to be sensitive to *only* the near field, the far field, or *both*! As such, no other RFID solution can offer this level of flexibility: only UHF Gen 2 allows a user to dial-in the optimal range for the application at hand. HF tags, on the other hand, are incapable of far-field operation.

Myth #7: UHF Gen 2 tags are more susceptible to noise, interference, and environmental conditions than HF tags

While Impinj's Monza-powered tags exhibit an extremely high level of receptivity (enabled through a patented combination of high sensitivity, or range, and interference rejection), this characteristic is of interest primarily in far-field operation. Once again, in near-field scenarios, it's a non-issue. In fact, where the near field is concerned, HF offers no noise immunity advantage over UHF.

UHF Gen 2 for Item-level Tagging

These seven myths persist only because critics of UHF Gen 2 for ILT have simply not taken into account UHF's outstanding near-field performance. This one, fundamental omission is at the root of arguments that look to favor HF over UHF. Typecasting UHF to play only in warehouse applications cuts users off from the deep, wide benefits of Gen 2, unnecessarily complicating deployments, and needlessly impacting ROI. Leveraging the advantages of UHF Gen 2 to ILT applications is a strategy that will simultaneously accelerate deployment success, make a significant contribution to ROI—and explode a few myths along the way.

One size fits all

The perfect RFID world: a single infrastructure that operates flawlessly in all regulatory environments, leverages a single reader and tag silicon solution, and can be easily tailored via application-specific tag antennas and reader accessories for maximum performance across pallet, case, and item-level applications. That's the promise of Gen 2—and the result delivered by Impinj's GrandPrix™ RFID solution comprising Monza tag silicon and the Speedway™ reader.

As a highly adaptable solution that exhibits both longevity and extensibility, Gen 2 also makes good business sense:

- High volumes and ease of manufacturing converge to drive costs down
- A robust protocol delivers the industry's highest read reliability
- Data rates as high as 640 kbps support large tag populations
- A technology roadmap that builds upon the existing Gen 2 standard so that your future RFID deployments will grow with you without the risk of infrastructure obsolescence
- Multi-supplier availability offers freedom from being locked into a proprietary RFID system

Attribute	HF	UHF
Near-field sensitivity (short range)	✓	✓
Far-field sensitivity (long range)		✓
Worldwide frequency band	✓	✓
Single worldwide protocol standard		✓
Low manufacturing cost		✓
Works on liquids and metals	✓	✓
Single infrastructure for item-level <i>and</i> pallet-level		✓
High data rate		✓

Suffice it to say from item-level to pallets, Europe to Asia, Gen 2 is all you need.

For RFID that just works™, visit www.impinj.com



701 N. 34th St.
Seattle, WA 98103
(206) 517-5300